

B099, Rev. -

1. Finish Goods PKG photo



2. Packing method

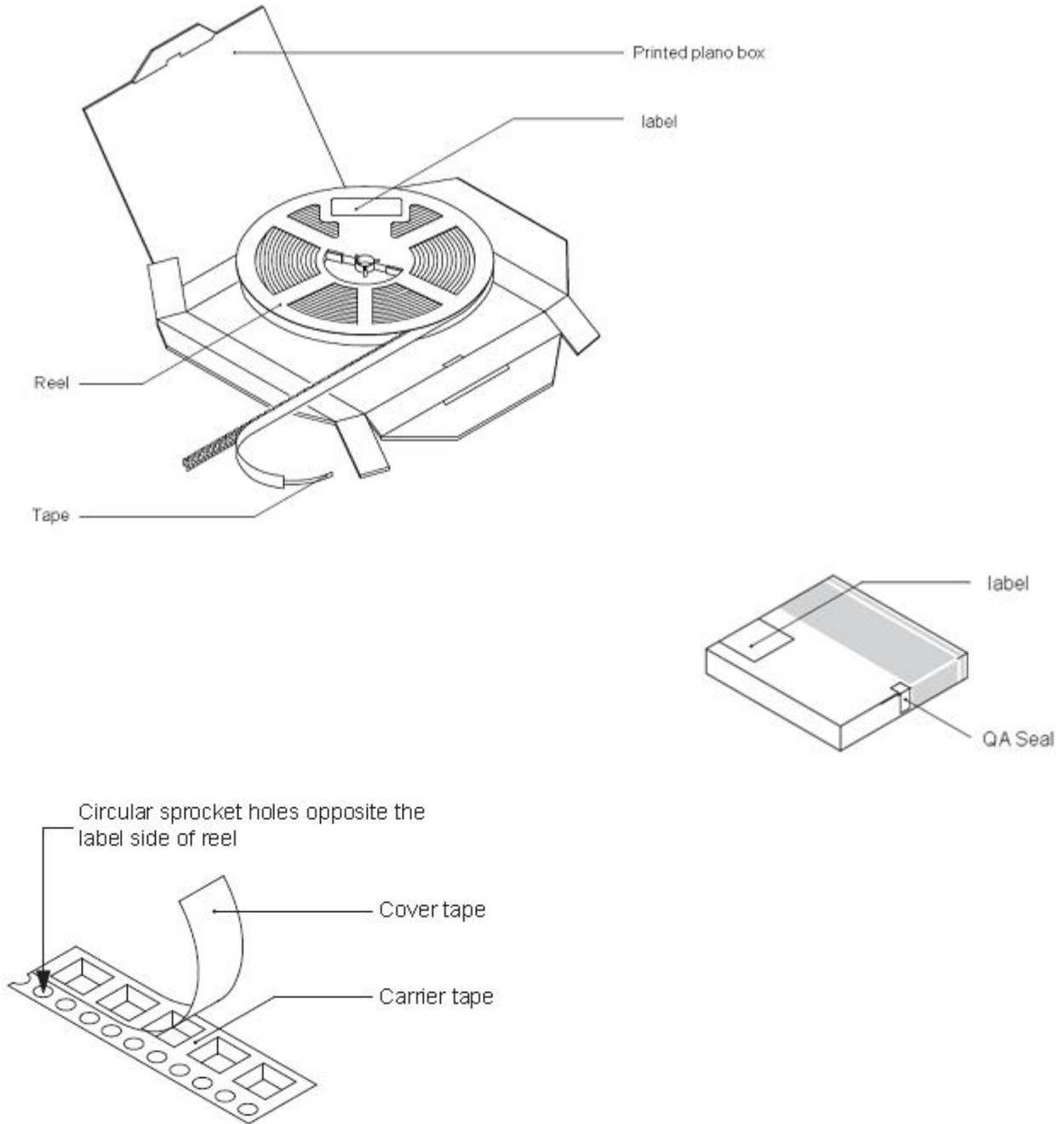

Fig.1- Reel pack for SOD882

Table 1. Packing information

Package version	Reel dimensions $\phi \times H$ (mm)	Pcs/reel (pcs)	Per reel weight (Kg)	Reels per box	Inner box weight (Kg)	Inner box dimensions L×W×H (mm)	Outer box weight (Kg)
SOD882	$\Phi 178 \times 11.5$	10000	0.0931	1	1.181	200*200*25	5.914

3. Product orientation

Standard product orientation SOD882

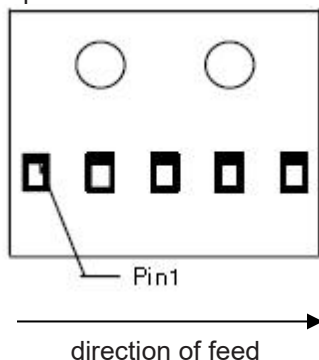
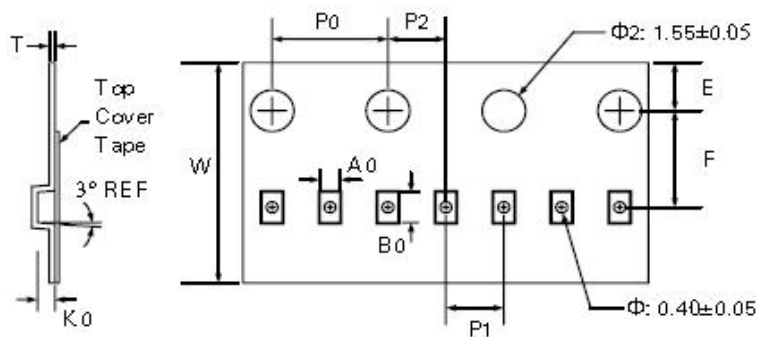

Fig 2. Product orientation in carrier tape

4. Carrier tape dimensions



Symbol	Tape Dimensions	
	Millimeters	
	Min	Max
A0	0.65	0.75
B0	1.10	1.20
K0	0.50	0.60
E	1.65	1.85
F	3.45	3.55
P0	3.90	4.10
P1	1.90	2.10
P2	1.95	2.05
T	1.95	2.05
W	7.90	8.10

Fig 3. Carrier tape dimensions

5. Reel dimensions

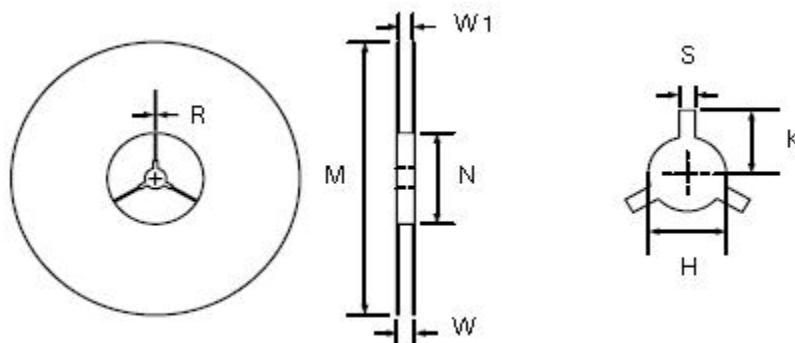

Symbol	Reel Dimensions (Size $\varnothing 178$)	
	Millimeters	
	Min	Max
M	177.0	179.0
N	59.0	61.0
W	11.0	12.0
W1	8.5	9.5
H	12.5	13.5
S	1.9	2.1
K	10.8	11.2
R	0.95	1.05

Fig 4. Reel dimensions